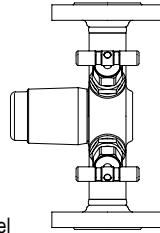


CONA® All-in-one - Steam trap station with integrated inlet and outlet valves
**CONA®B All-in-one
Bimetallic steam trap
PN40**

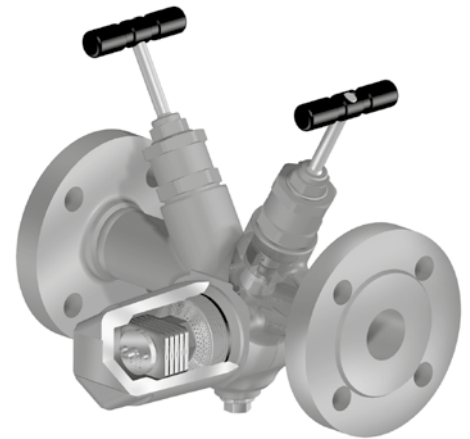
- with flanges
- with screwed sockets
- with socket weld ends
- with butt weld ends

(Fig. 60A....1)
(Fig. 60A....2)
(Fig. 60A....3)
(Fig. 60A....4)

Forged steel
Stainless steel
Fig. 60A



Page 2



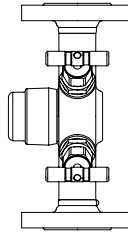
CONA®B All-in-one

**CONA®M All-in-one
Thermostatic steam trap
PN40**

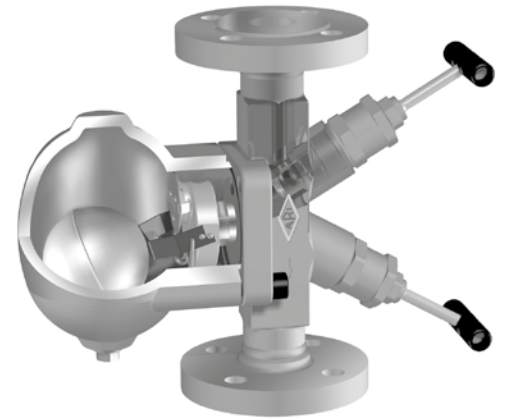
- with flanges
- with screwed sockets
- with socket weld ends
- with butt weld ends

(Fig. 61A....1)
(Fig. 61A....2)
(Fig. 61A....3)
(Fig. 61A....4)

Forged steel
Stainless steel
Fig. 61A



Page 4

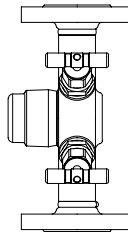

 CONA®SC All-in-one
(shown with optional drain plug)

**CONA®TD All-in-one
Thermodynamic steam trap
PN40**

- with flanges
- with screwed sockets
- with socket weld ends
- with butt weld ends

(Fig. 64A....1)
(Fig. 64A....2)
(Fig. 64A....3)
(Fig. 64A....4)

Forged steel
Stainless steel
Fig. 64A



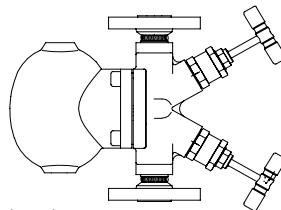
Page 6

**CONA®SC All-in-one
Ball float steam trap
PN40**

- with flanges
- with screwed sockets
- with socket weld ends
- with butt weld ends

(Fig. 63A....1)
(Fig. 63A....2)
(Fig. 63A....3)
(Fig. 63A....4)

Forged steel
Stainless steel
Fig. 63A



Page 10

New!
 Face-to-face dimension FTF-113
 acc. to DIN EN 558

Features:

- Robust and resistant to water-hammer
- Integrated non return protection
- Mounting position vertical or horizontal
- The controller maybe changed without disturbing the pipe work

CONA®B/M/TD All-in-one:

- For discharging of slight to highly sub-cooled condensate
- Optimized design for quick installation
- Gasket-free sealing
- Internal strainer

CONA®SC All-in-one:

- No build-up of condensate due to immediate discharge
- Rapid system start-up due to thermostatic airventing capsule

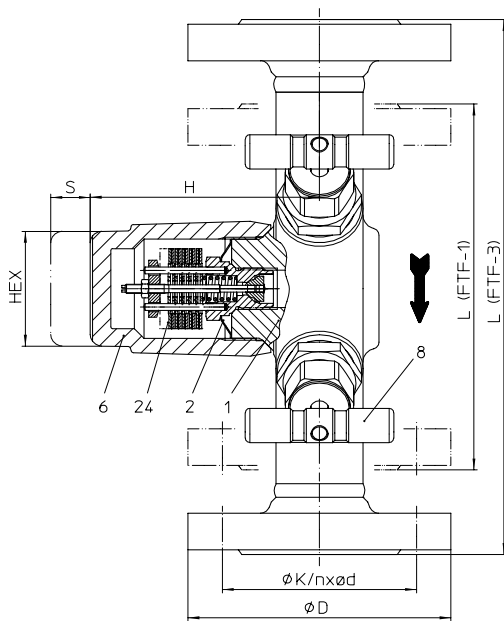
CONA®B All-in-one - Bimetallic steam trap with integrated inlet and outlet valves
 (Forged steel, Stainless steel)


Fig. 60A...1 with flanges (inlet-right)

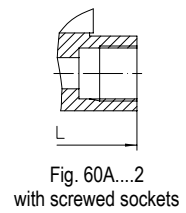
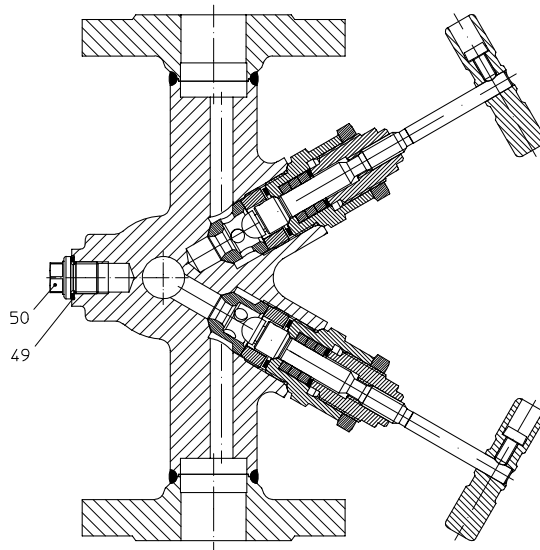
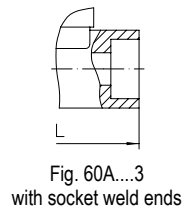
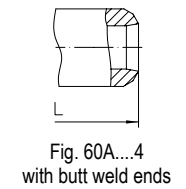

 Fig. 60A...2
with screwed sockets

 Fig. 60A...3
with socket weld ends

 Fig. 60A...4
with butt weld ends

Figure	Nominal pressure	Material	Nominal diameter / NPS	Operating pressure PS	Inlet temperature TS	allowable differential pressure ΔPMX	for controller
45.60A	PN40	1.0460	DN15-25 / 1/2" - 1"	32 barg	250 °C	32 bar 22 bar 13 bar	R32 R22 R13
				22 barg	385 °C		
				14,5 barg	450 °C		
55.60A	PN40	1.4541	DN15-25 / 1/2" - 1"	32 barg	350 °C		
				22 barg	400 °C		

For ANSI versions refer to data sheet CONA®All-in-one ANSI

Types of connection Other types of connection on request.

- Flanges1 _____ acc. to DIN EN 1092-1
- Screwed sockets2 _____ Rp thread acc. to DIN EN 10226-1 or NPT thread acc. to ANSI B1.20.1
- Socket weld ends3 _____ acc. to DIN EN 12760
- Butt weld ends4 _____ Weld preparation acc. to EN ISO 9692 identification No. 1.3 and 1.5
(Note restriction on operating pressure / inlet temperature depending to design!)

Features

- Thermostatic steam trap with non-corrosive and robust water hammer proof bimetallic controller
- User-friendly handling, easy and quick access to the controller
- Automatic air-venting during start up and operation of the plant
- Non return protection
- With inside strainer
- Maintenance simplified due to screwed cap without sealing
- The controller maybe changed without disturbing the pipe work

Mounting position

• Standard:	vertical horizontal; inlet-right	Please indicate when ordering!
• Optional:	horizontal; inlet-left	

Controller (chooseable for operating range)

• Controller R13	uo to inlet pressure: 13 bar
• Controller R22	uo to inlet pressure: 22 bar
• Controller R32	uo to inlet pressure: 32 bar

Options (Design refer to page 3)

- Drain valve (Pos. 51)
- Ball valve for blow down (Pos. 56)
- Stop valve with bellows seal (Pos. 8)

Types of connection	Flanges ¹⁾			Screwed sockets ²⁾ Socket weld ends ²⁾			Butt weld ends ²⁾		
	DN	15	20	25	15	20	25	15	20
NPS	1/2"	3/4"	1"	1/2"	3/4"	1"	1/2"	3/4"	1"

Face-to-face											
L	FTF-1	(mm)	150	150	160	150	150	230	160	160	160
	FTF-3	(mm)	210	210	230						

¹⁾ Face-to-face acc. to DIN EN 26554 FTF-1 / FTF-3

²⁾ Face-to-face acc. to datasheet resp. customer request

Dimensions										
H	(mm)	100	100	100	100	100	100	100	100	100
S	(mm)	70	70	70	70	70	70	70	70	70
HEX	(mm)	50	50	50	50	50	50	50	50	50

Standard-flange dimensions refer to page 12.

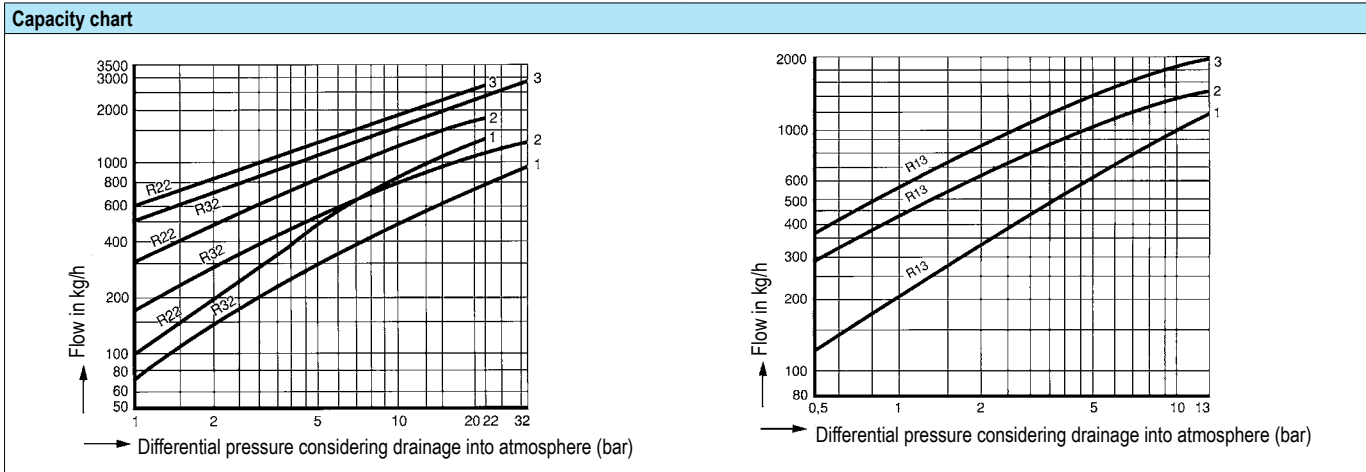
Weights											
Fig. 60A	FTF-1 (approx.)	(kg)	4,8	5,3	5,8	4,1	4,4	6,6	4,1	4	3,9
	FTF-3 (approx.)	(kg)	5,6	6,1	6,6						

Parts										
Pos.	Sp.p.	Description	Fig. 45.60A	Fig. 55.60A						
1		Body	P250 GH, 1.0460	X6CrNiTi18-10, 1.4541						
2	x	Strainer	X5CrNi18-10, 1.4301							
6		Cap	P250 GH, 1.0460	X6CrNiTi18-10, 1.4541						
8	x	Assembly stop valve, cpl.	X8CrNiS18-9, 1.4305							
24	x	Controller, cpl.	TB 102 / 85 (corrosion resistant bimetal)							
49	x	Sealing ring	A4							
50	x	Screw plug (M14x1,5)	X6CrNiTi18-10, 1.4541							
51	x	Drain valve	X8CrNiS18-9, 1.4305							
56	x	Ball valve for blow down	GX5CrNiMo19-11-2, 1.4408							
L Spare parts										

Information / restriction of technical rules need to be observed!

Operating and installation instructions can be downloaded at www.ari-armaturen.com.

Resistance and fitness must be verified (contact manufacturer for information, refer to Product overview and Resistance list).



The capacity chart shows the maximum capacity at factory setting.

Curve 1: Maximum flow of hot condensate at approx. 10 K below saturation temperature.

Curve 2: Maximum flow of sub-cooled condensate at approx. 30 K below saturation temperature (with back-up of condensate).

Curve 3: Maximum flow at cold condensate at about 20°C (during start-up of a cold installation).

The condensate temperature determines the opening of the controller. Capacity is increased with the sub-cooling temperature of the condensate.

Options		
<p>Drain valve</p>	<p>Ball valve for blow down (restricted to 13 bar, 200°C)</p>	<p>Stop valve with bellows seal</p>

CONA® M All-in-one - Thermostatic steam trap with integrated inlet and outlet valves
(Forged steel, Stainless steel)

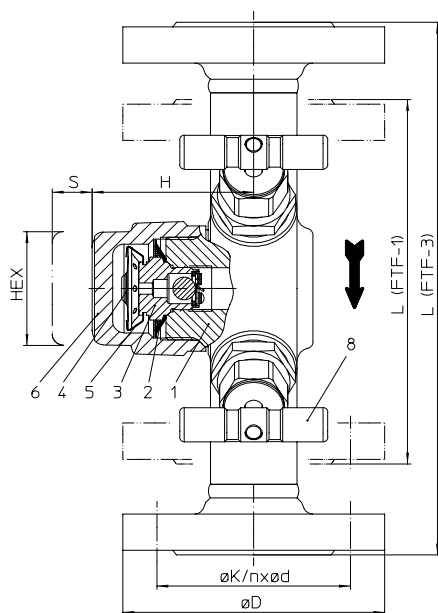


Fig. 61A...1 with flanges (inlet-right)

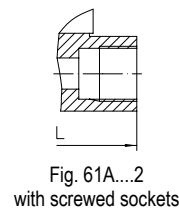
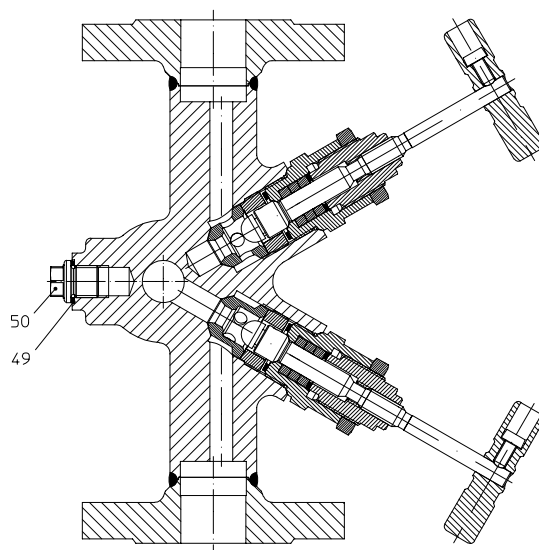


Fig. 61A...2
with screwed sockets

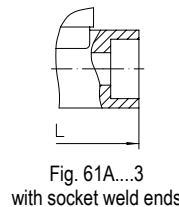


Fig. 61A...3
with socket weld ends

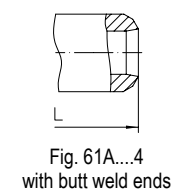


Fig. 61A...4
with butt weld ends

Figure	Nominal pressure	Material	Nominal diameter / NPS	Operating pressure PS	Inlet temperature TS	allowable differential pressure ΔPMX	for controller
45.61A	PN40	1.0460	DN15-25 / 1/2" - 1"	32 barg	250 °C	32 bar	R32
				22 barg	385 °C		
				14,5 barg	450 °C		
55.61A	PN40	1.4541	DN15-25 / 1/2" - 1"	32 barg	350 °C	32 bar	R32
				22 barg	400 °C		

For ANSI versions refer to data sheet CONA®All-in-one ANSI

Types of connection

Other types of connection on request.

- Flanges1 _____ acc. to DIN EN 1092-1
- Screwed sockets2 ____Rp thread acc. to DIN EN 10226-1 or NPT thread acc. to ANSI B1.20.1
- Socket weld ends3 ____ acc. to DIN EN 12760
- Butt weld ends4 _____ Weld preparation acc. to EN ISO 9692 identification No. 1.3 and 1.5
(Note restriction on operating pressure / inlet temperature depending to design!)

Features

- Thermostatic steam trap with noncorrosive and robust water hammer proofed capsule
- User-friendly handling, easy and quick access to the controller
- Non return protection
- With inside strainer
- Filter effect maximised at horizontal installation
- Optimized design for quick installation
- Maintenance simplified due to screwed cap without sealing
- The controller maybe changed without disturbing the pipe work

Mounting position

• Standard:	vertical	Please indicate when ordering!
	horizontal; inlet-right	
• Optional:	horizontal; inlet-left	

Capsule:

(chooseable for operating range)

• Capsule No. 1	for condensate discharge close to boiling temperature (only on request)
• Capsule No. 2	for condensate sub-cooling about approx. 10K (Standard)
• Capsule No. 3	for condensate sub-cooling about approx. 30K

Options (Design refer to page 5)

- Drain valve (Pos. 51)
- Ball valve for blow down (Pos. 56)
- Stop valve with bellows seal (Pos. 8)

Types of connection	Flanges ¹⁾			Screwed sockets ²⁾ Socket weld ends ²⁾			Butt weld ends ²⁾		
	DN	15	20	25	15	20	25	15	20
NPS	1/2"	3/4"	1"	1/2"	3/4"	1"	1/2"	3/4"	1"

Face-to-face											
L	FTF-1	(mm)	150	150	160	150	150	230	160	160	160
	FTF-3	(mm)	210	210	230						

¹⁾ Face-to-face acc. to DIN EN 26554 FTF-1 / FTF-3

²⁾ Face-to-face acc. to datasheet resp. customer request

Dimensions										
H	(mm)	70	70	70	70	70	70	70	70	70
S	(mm)	40	40	40	40	40	40	40	40	40
HEX	(mm)	50	50	50	50	50	50	50	50	50

Standard-flange dimensions refer to page 12.

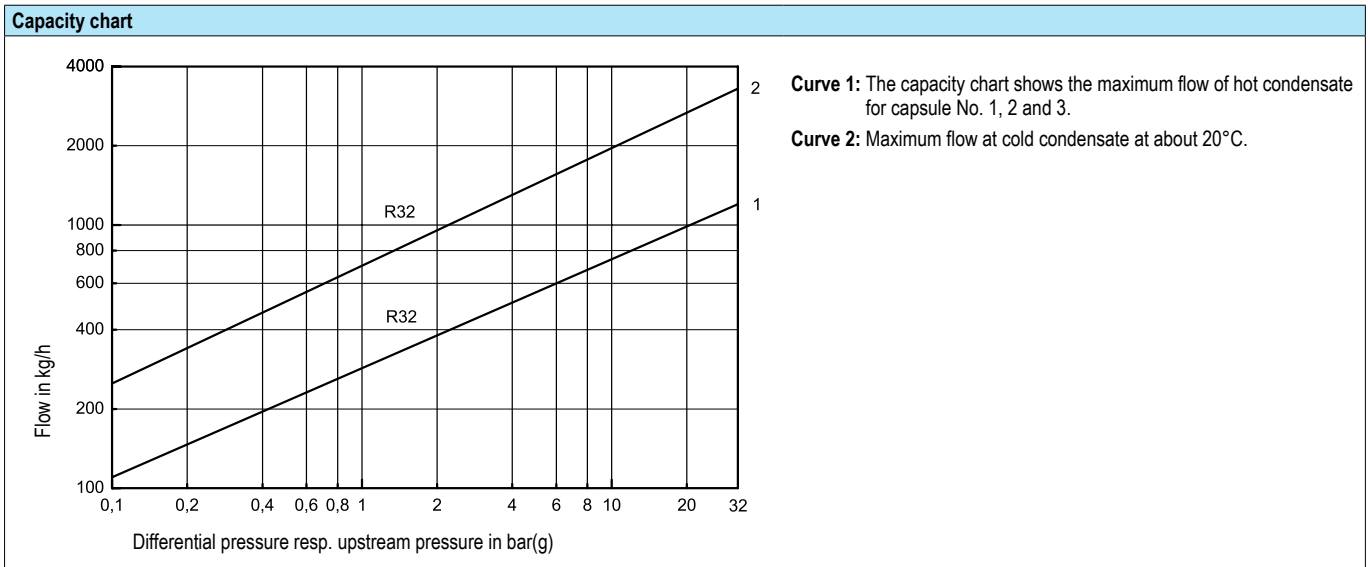
Weights											
Fig. 61A	FTF-1 (approx.)	(kg)	4,3	4,8	5,3	3,3	3,2	3,7	3,4	3,3	3,2
	FTF-3 (approx.)	(kg)	4,8	5,3	5,8						

Parts										
Pos.	Sp.p.	Description	Fig. 45.61A	Fig. 55.61A						
1		Body	P250 GH, 1.0460	X6CrNiTi18-10, 1.4541						
2	x	Strainer	X5CrNi18-10, 1.4301							
3	x	Seat	X8CrNiS18-9, 1.4305							
4	x	Capsule (Diaphragm / Capsule)	Hastelloy / X5CrNi18-10, 1.4301							
5	x	Spring actuated clip	X10CrNi8-8, 1.4310							
6		Cap	P250 GH, 1.0460	X6CrNiTi18-10, 1.4541						
8	x	Assembly stop valve, cpl.	X8CrNiS18-9, 1.4305							
49	x	Sealing ring	A4							
50	x	Screw plug (M14x1,5)	X6CrNiTi18-10, 1.4541							
51	x	Drain valve	X8CrNiS18-9, 1.4305							
56	x	Ball valve for blow down	GX5CrNiMo19-11-2, 1.4408							
↳ Ersatzteile										

Information / restriction of technical rules need to be observed!

Operating and installation instructions can be downloaded at www.ari-armaturen.com.

Resistance and fitness must be verified (contact manufacturer for information, refer to Product overview and Resistance list).



Options

Drain valve

Ball valve for blow down
(restricted to 13 bar, 200°C)

Stop valve with bellows seal

CONA®TD All-in-one - Thermodynamic steam trap with integrated inlet and outlet valves
(Forged steel, Stainless steel)

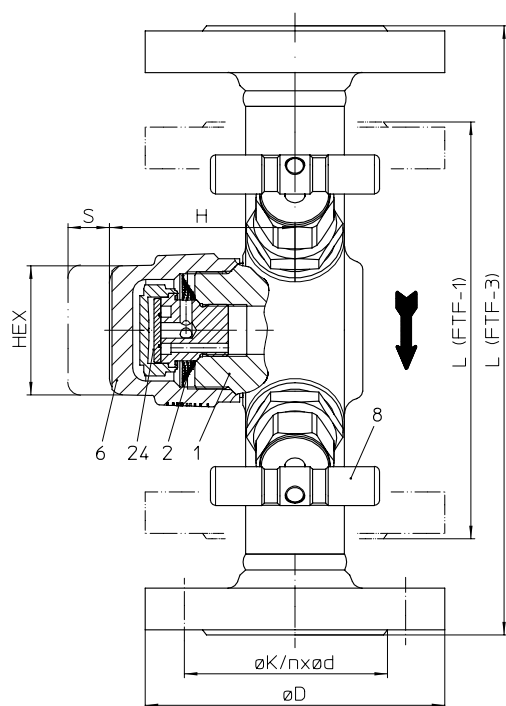


Fig. 64A....1 with flanges (inlet-right)

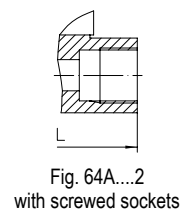
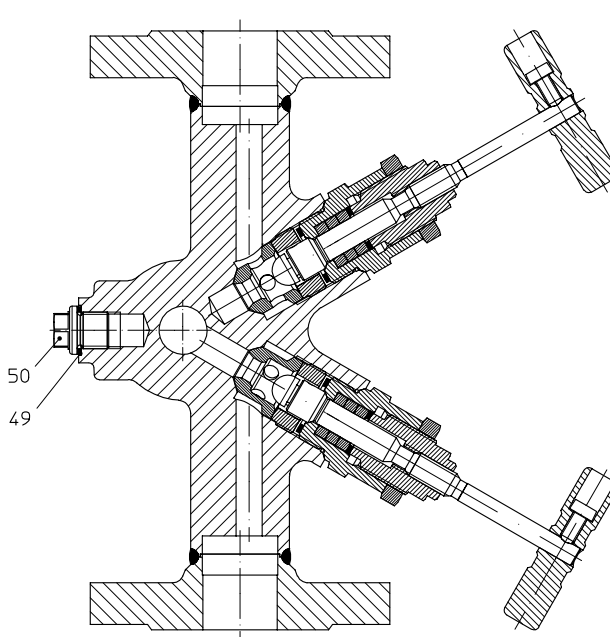


Fig. 64A....2 with screwed sockets

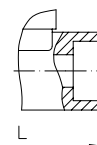


Fig. 64A....3 with socket weld ends

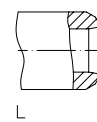


Fig. 64A....4 with butt weld ends

Figure	Nominal pressure	Material	Nominal diameter / NPS	Operating pressure PS	Inlet temperature TS	allowable differential pressure ΔPMX	permissible pressure ratio
45.64A	PN40	1.0460	DN15-25 / 1/2" - 1"	32 barg	250 °C	32 bar	Back pressure / Inlet pressure ≤ 0,8
				22 barg	385 °C		
				14,5 barg	450 °C		
55.64A	PN40	1.4541	DN15-25 / 1/2" - 1"	32 barg	350 °C	32 bar	Back pressure / Inlet pressure ≤ 0,8
				22 barg	400 °C		

For ANSI versions refer to data sheet CONA®All-in-one ANSI

Types of connection Other types of connection on request.

- Flanges1 _____ acc. to DIN EN 1092-1
- Screwed sockets2 _____ Rp thread acc. to DIN EN 10226-1 or NPT thread acc. to ANSI B1.20.1
- Socket weld ends3 _____ acc. to DIN EN 12760
- Butt weld ends4 _____ Weld preparation acc. to EN ISO 9692 identification No. 1.3 and 1.5
(Note restriction on operating pressure / inlet temperature depending to design!)

Features

- Thermodynamic steam trap with replaceable controller-unit and cap with heat chamber wich minimize the effects from the weather conditions to the function of the trap such as low ambient temperatures, rain, wind, etc.
- User-friendly handling, easy and quick access to the controller
- Intermittent mode of operation
- Heat chamber minimizes the impact of weather conditions on the trap's performance
- Robust and resistant to water-hammer
- Integrated non return protection
- With inside strainer
- Optimized design for quick installation
- Maintenance simplified due to screwed cap without sealing
- The controller maybe changed without disturbing the pipe work

Mounting position

• Standard:	vertical	Please indicate when ordering!
	horizontal; inlet-right	
• Optional:	horizontal; inlet-left	

Options (Design refer to page 7)

- Drain valve (Pos. 51)
- Ball valve for blow down (Pos. 56)
- Stop valve with bellows seal (Pos. 8)

Types of connection	Flanges ¹⁾			Screwed sockets ²⁾ Socket weld ends ²⁾			Butt weld ends ²⁾		
	DN	15	20	25	15	20	25	15	20
NPS	1/2"	3/4"	1"	1/2"	3/4"	1"	1/2"	3/4"	1"

Face-to-face											
L	FTF-1	(mm)	150	150	160	150	150	230	160	160	160
	FTF-3	(mm)	210	210	230						

¹⁾ Face-to-face acc. to DIN EN 26554 FTF-1 / FTF-3

²⁾ Face-to-face acc. to datasheet resp. customer request

Dimensions										
H	(mm)	70	70	70	70	70	70	70	70	70
S	(mm)	40	40	40	40	40	40	40	40	40
HEX	(mm)	50	50	50	50	50	50	50	50	50

Standard-flange dimensions refer to page 12.

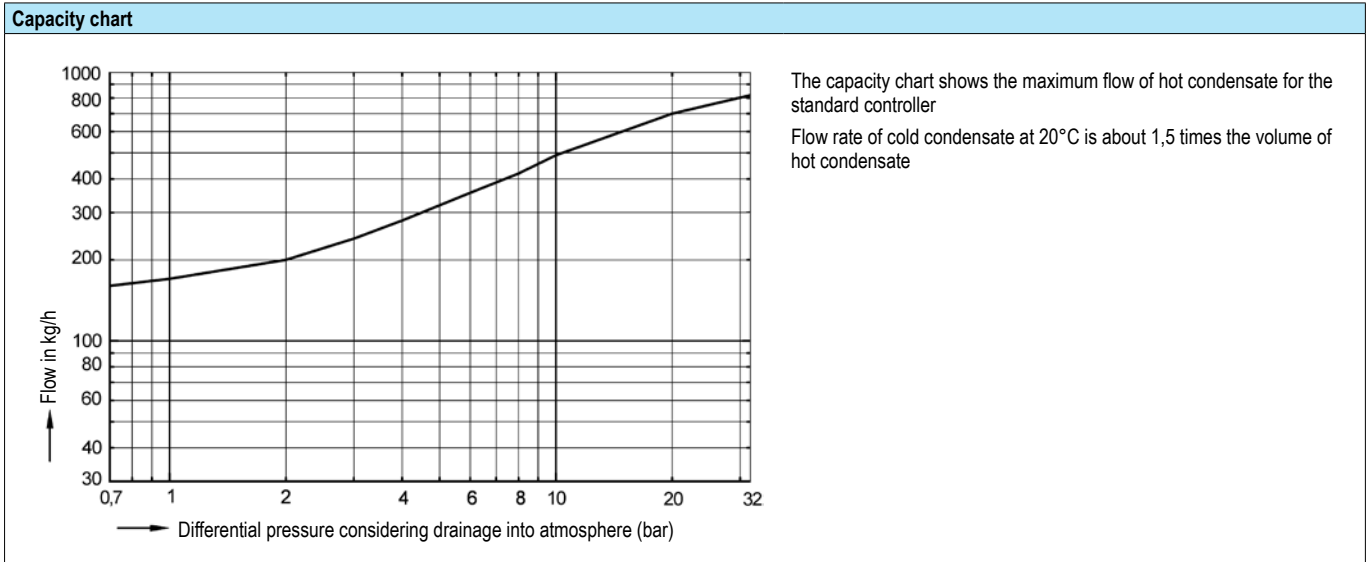
Weights											
Fig. 64A	FTF-1 (approx.)	(kg)	4,3	4,8	5,3	3,3	3,2	3,7	3,4	3,3	3,2
	FTF-3 (approx.)	(kg)	4,8	5,3	5,8						

Parts										
Pos.	Sp.p.	Description	Fig. 45.64A	Fig. 55.64A						
1		Body	P250 GH, 1.0460	X6CrNiTi18-10, 1.4541						
2	x	Strainer	X5CrNi18-10, 1.4301							
6		Cap	P250 GH, 1.0460	X6CrNiTi18-10, 1.4541						
8	x	Assembly stop valve, cpl.	X8CrNiS18-9, 1.4305							
24	x	Controller, cpl.	X39CrMo17-1+QT, 1.4122+QT							
49	x	Sealing ring	A4							
50	x	Screw plug (M14x1,5)	X6CrNiTi18-10, 1.4541							
51	x	Drain valve	X8CrNiS18-9, 1.4305							
56	x	Ball valve for blow down	GX5CrNiMo19-11-2, 1.4408							
L Spare parts										

Information / restriction of technical rules need to be observed!

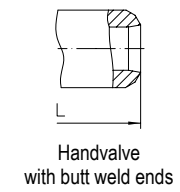
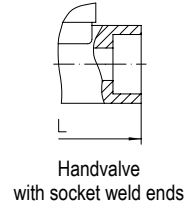
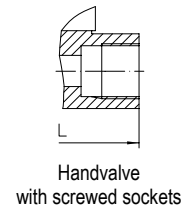
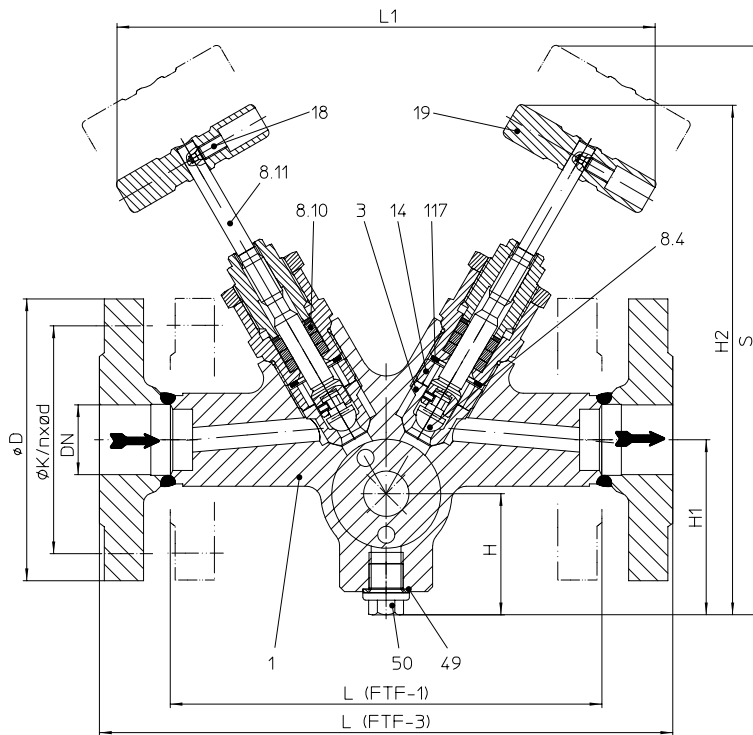
 Operating and installation instructions can be downloaded at www.ari-armaturen.com.

Resistance and fitness must be verified (contact manufacturer for information, refer to Product overview and Resistance list).

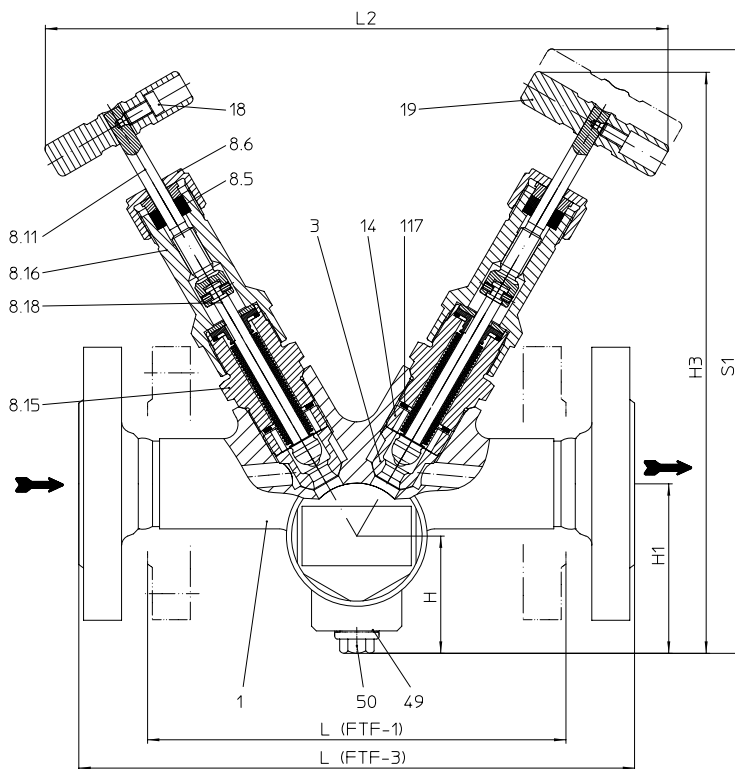


Options		
<p>Drain valve</p>	<p>Ball valve for blow down (restricted to 13 bar, 200°C)</p>	<p>Stop valve with bellows seal</p>

Handvalve for inlet and outlet (Forged steel, Stainless steel)



Stop valve with gland packing (inlet-right)



Stop valve with bellows seal (inlet-right)

Options
<p>51</p> <p>Drain valve</p>
<p>56</p> <p>Ball valve for blow down (restricted to 13 bar, 200°C)</p>

Types of connection	Flanges ¹⁾			Screwed sockets ²⁾ / Socket weld ends ²⁾			Butt weld ends ²⁾			
	DN	15	20	25	15	20	25	15	20	25
NPS	1/2"	3/4"	1"	1/2"	3/4"	1"	1/2"	3/4"	1"	

Face-to-face											
L	FTF-1	(mm)	150	150	160	150	150	230	160	160	160
	FTF-3	(mm)	210	210	230						

¹⁾ Face-to-face acc. to DIN EN 26554 FTF-1 / FTF-3

²⁾ Face-to-face acc. to datasheet resp. customer request

Dimensions											
L1	(mm)	220	220	220	220	220	220	220	220	220	220
L2 (bellows seal)	(mm)	259	259	259	259	259	259	259	259	259	259
H	(mm)	50	50	50	50	50	50	50	50	50	50
H1	(mm)	72 ³⁾	72 ³⁾	72 ³⁾	72	72	72	72	72	72	72
H2	(mm)	208	208	208	208	208	208	208	208	208	208
H3 (bellows seal)	(mm)	241	241	241	241	241	241	241	241	241	241
S	(mm)	217	217	217	217	217	217	217	217	217	217
S1 (bellows seal)	(mm)	250	250	250	250	250	250	250	250	250	250

Standard-flange dimensions refer to page 12.

³⁾ FTF-3

Parts				
Pos.	Sp.p.	Description	Forged steel	Stainless steel
1		Body	P250GH, 1.0460	X6CrNiTi18-10, 1.4541
3	x	Seat	X8CrNiS18-9, 1.4305	
8	x cpl. unit	Assembly stop valve, cpl.	X8CrNiS18-9, 1.4305	
8.4		Valve ball	X39CrMo17-1+QT, 1.4122+QT	
8.5		Packing ring	Pure graphite	
8.6		Sleeve nut	X14CrMoS17+QT, 1.4104+QT	
8.10		Packing ring	Pure graphite	
8.11		Stem	Bland packing: X2CrNiMo17-12-2, 1.4404 Bellows seal: X39CrMo17-1+QT, 1.4122+QT	
8.15		Fitting	X8CrNiS18-9, 1.4305	
8.16		Stem guiding	X8CrNiS18-9, 1.4305	
8.18		Stem unit	X5CrNi18-10, 1.4301	
14	x	Banjo bolt	X8CrNiS18-9, 1.4305	
18	x	Cheese head screw	A2-70	
19	x	Hand grip	X14CrMoS17+QT, 1.4104+QT	
49	x	Sealing ring	A4	
50	x	Screw plug (M14x1,5)	X6CrNiTi18-10, 1.4541	
51	x	Drain valve (M14x1,5)	X8CrNiS18-9, 1.4305	
56	x	Ball valve for blow down	GX5CrNiMo19-11-2, 1.4408	
117	x	Sealing ring	Graphit	
Option: Hand wheel				
18	x	Grub screw	A2-70	
19	x	Hand wheel	GX5CrNiMo19-11-2, 1.4408	
		L Spare parts		

Information / restriction of technical rules need to be observed!

 Operating and installation instructions can be downloaded at www.ari-armaturen.com.

Resistance and fitness must be verified (contact manufacturer for information, refer to Product overview and Resistance list).

Combinations	
	<p>CONA®B All-in-one</p> <p>CONA®M All-in-one</p> <p>CONA®TD All-in-one</p> <p>Stop valve with gland packing (with flanges, screwed sockets, socket weld ends, butt weld ends)</p> <p>Options Stop valve with bellows seal</p>

CONA®SC All-in-one - Ball float steam trap with integrated inlet and outlet valves
(Forged steel, Stainless steel)

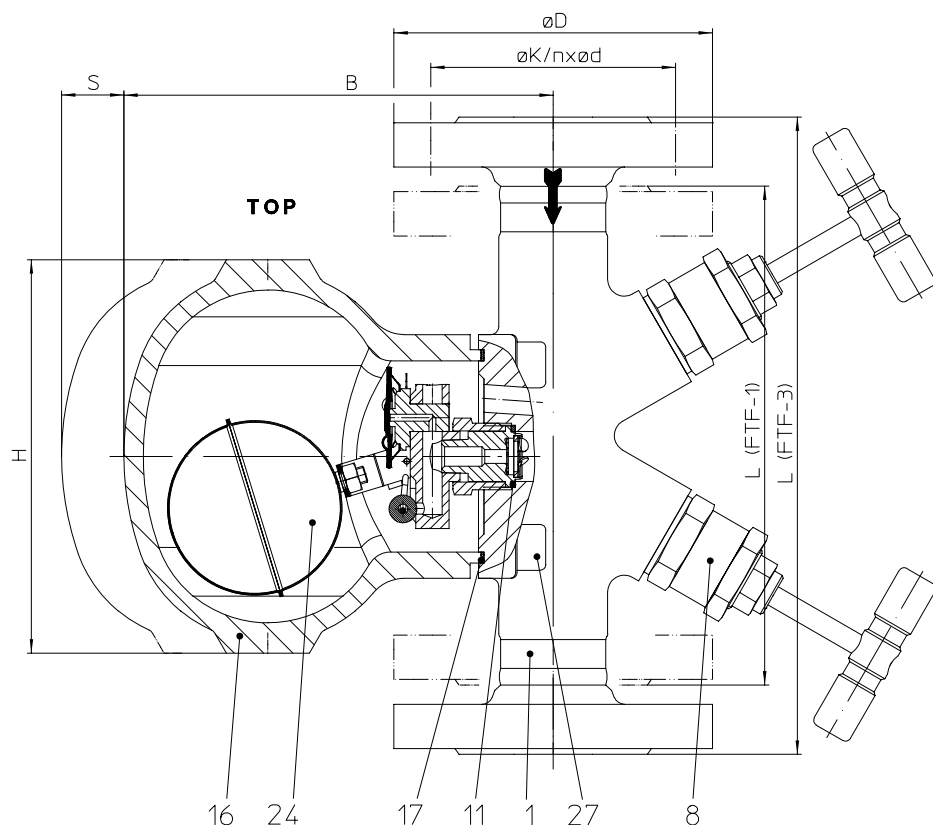


Fig. 63A...1 with flanges (inlet-vertical)

Fig. 63A...2 with screwed sockets

Fig. 63A...3 with socket weld ends

Fig. 63A...4 with butt weld ends

Figure	Nominal pressure	Material	Nominal diameter / NPS	Operating pressure PS	Inlet temperature TS	allowable differential pressure ΔPMX	for controller
45.63A	PN40	Hood: 1.0619+N	DN15-25 / 1/2" - 1"	4 barg	400 °C	32 bar	R32
				14 barg			
				21 barg			
				32 barg	250 °C		
55.63A	PN40	Hood: 1.4308	DN15-25 / 1/2" - 1"	4 barg	300 °C	14 bar	R14
				14 barg		4 bar	R4
				21 barg	250 °C		
				32 barg			

For ANSI versions refer to data sheet CONA®All-in-one ANSI

Types of connection Other types of connection on request.

- Flanges1 _____ acc. to DIN EN 1092-1
- Screwed sockets2 ____Rp thread acc. to DIN EN 10226-1 or NPT thread acc. to ANSI B1.20.1
- Socket weld ends3 ____ acc. to DIN EN 12760
- Butt weld ends4 _____ Weld preparation acc. to EN ISO 9692 identification No. 1.3 and 1.5
(Note restriction on operating pressure / inlet temperature depending to design!)

Features

- Ball float steam trap with level control for the condensate-discharge from all kinds of steam systems
- Rapid system start-up due to thermostatic air venting capsule
- User-friendly handling, easy and quick access to the controller
- Immediate discharge of hot boiling condensat
- Discharge of great condensate quantities even at low differential pressure
- Body with flanged hood
- Non return protection
- The controller maybe changed without disturbing the pipe work

Mounting position:

- Standard: vertical
 - Optional: horizontal with inlet from right
 - Optional: horizontal with inlet from left
- Please indicate when ordering!**
Installation position may be changed on-site (see operating instructions).
Definition: Globe valves facing the operator, bonnet at the rear, top side up.

Options (Design refer to page 11)

- Vent plug (Pos. 47)
- Plug (Pos. 50)
- Manual air vent valve (Pos. 51)
- Ball valve for blow down (Pos. 56)
- Stop valve with bellows seal

Types of connection	Flanges ¹⁾			Screwed sockets ²⁾ Socket weld ends ²⁾			Butt weld ends ²⁾		
	DN	15	20	25	15	20	25	15	20
NPS	1/2"	3/4"	1"	1/2"	3/4"	1"	1/2"	3/4"	1"

Face-to-face											
L	FTF-1	(mm)	150	150	160	150	150	230	160	160	160
	FTF-3	(mm)	210	210	230						

¹⁾ Face-to-face acc. to DIN EN 26554 FTF-1 / FTF-3

²⁾ Face-to-face acc. to datasheet resp. customer request

Dimensions										
Standard-flange dimensions refer to page 12.										
H	(mm)	150	150	150	150	150	150	150	150	150
B	(mm)	156	156	156	156	156	156	156	156	156
S	(mm)	112	112	112	112	112	112	112	112	112

Weights											
Fig. 63A	FTF-1 (approx.)	(kg)	6,5	7,2	7,7	5,6	5,5	6	5,5	5,4	5,3
	FTF-3 (approx.)	(kg)	7	7,7	8,2						

Parts										
Pos.	Sp.p.	Description	Fig. 45.63A	Fig. 55.63A						
1		Body	P250 GH, 1.0460	X6CrNiTi18-10, 1.4541						
8	x	Assembly stop valve, cpl.	X8CrNiS18-9, 1.4305							
11	x	Sealing ring	A4							
16		Hood	GP240GH+N, 1.0619+N	GX5CrNi19-10, 1.4308						
17	x	Gasket	GRAPHIT (mit CrNi-Stahlfolieneinlage)							
24	x	Controller / Capsule, cpl.	X5CrNi18-10, 1.4301 / Hastelloy							
27		Cheese head screw	21CrMoV 5-7, 1.7709	A2-70						
47		Vent plug (M14x1,5)	X6CrNiTi18-10, 1.4541							
49	x	Sealing ring	A4							
50	x	Screw plug (M14x1,5)	X6CrNiTi18-10, 1.4541							
51	x	Drain valve	X8CrNiS18-9, 1.4305							
56	x	Ball valve for blow down	GX5CrNiMo19-11-2, 1.4408							
L Spare parts										

Information / restriction of technical rules need to be observed!

Operating and installation instructions can be downloaded at www.ari-armaturen.com.

Resistance and fitness must be verified (contact manufacturer for information, refer to Product overview and Resistance list).

Capacity chart																																		
	<p>The capacity chart shows the maximum flow of hot boiling condensate. The total cold water capacity is the result of:</p> <ul style="list-style-type: none"> - The capacity of the trap is increased by 1,2 x the value shown in the capacity chart. - The thermostatic air vent is open, provided additional capacity as shown in the table <table border="1"> <thead> <tr> <th colspan="11">Additional cold water-flow quantity of the thermostatic steam trap at starting conditions</th> </tr> <tr> <th>Δp</th> <th>(bar)</th> <th>1</th> <th>2</th> <th>3</th> <th>4</th> <th>5</th> <th>6</th> <th>8</th> <th>10</th> <th>21</th> </tr> </thead> <tbody> <tr> <td>Q</td> <td>(approx.20°C) (kg/h)</td> <td>280</td> <td>360</td> <td>440</td> <td>490</td> <td>550</td> <td>590</td> <td>640</td> <td>710</td> <td>990</td> </tr> </tbody> </table>	Additional cold water-flow quantity of the thermostatic steam trap at starting conditions											Δp	(bar)	1	2	3	4	5	6	8	10	21	Q	(approx.20°C) (kg/h)	280	360	440	490	550	590	640	710	990
Additional cold water-flow quantity of the thermostatic steam trap at starting conditions																																		
Δp	(bar)	1	2	3	4	5	6	8	10	21																								
Q	(approx.20°C) (kg/h)	280	360	440	490	550	590	640	710	990																								

Options	
Ball valve for blow down (restricted to 13 bar, 200°C)	Stop valve with bellows seal

Informations about pipe welding
Welding groove acc. to DIN 2559

The material used for ARI valves with butt weld ends are: 1.0460 P250GH acc. to DIN EN 10222-2

Note: 1.4541 X6CrNiTi18-10 acc. to DIN EN 10222-5

Note restriction on operating pressure / inlet temperature depending to design!

Due to our experience, we recommend to apply an electric welding process.

Because of the different material compositions and wall thickness of the steam traps and the pipe gas welding shall not be applied. Quenching cracks and coarse grain structure may develop.

Steam traps with socket-weld ends shall only be welded by arc welding (welding process 111 acc. to DIN EN 24063).

If during the time of warranty others than the manufacturer or by the manufacturer authorized persons are interfering in the product and/or the setting, the right of claim for warranty will lapse!

Standard - Flange dimensions acc. to DIN EN 1092-1

DN			15	20	25
NPS			1/2"	3/4"	1"
PN40	ØD	(mm)	95	105	115
	ØK	(mm)	65	75	85
	n x Ød	(mm)	4 x 14	4 x 14	4 x 14